

Success Story

SupplyPoint® is a web-enabled proprietary database designed to help small and medium sized enterprises (SMEs) expand their business by assisting them in the quote submission process. The program works by matching your company's profile with the quote requirements. Currently, more than 6,500 SMEs are registered in SupplyPoint.®

SupplyPoint® is ready to assist the small manufacturer to access the power of The Center for Supply Chain Integration and Risk Management.

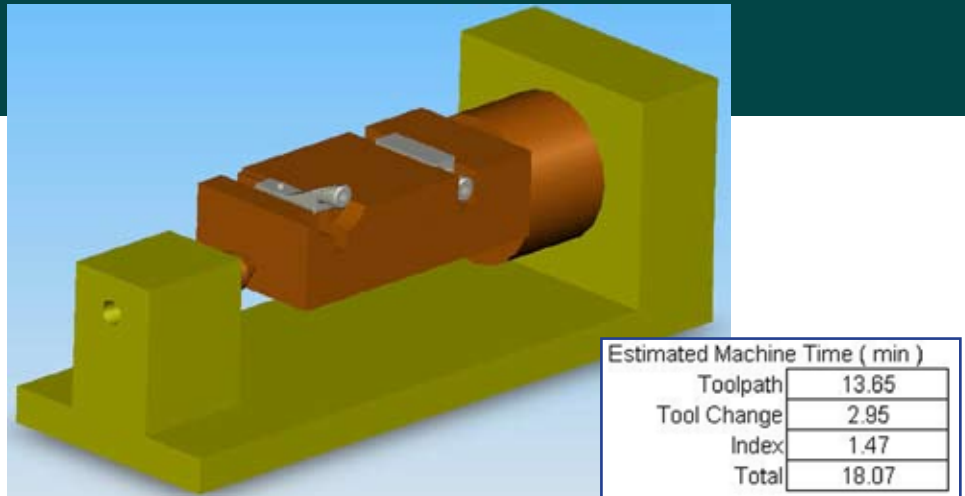

Reduced Cycle Time Plus Cost Savings Increases Opportunity for Success

Requirement:

A small machine shop, having very little success in the quote submission process and being awarded federal contracts, contacted SupplyPoint® for an assessment of their CNC production cycle time. Working through their normal quoting and production process for one particular part, the cycle time took 26 minutes and required five different set-ups. Using this cycle time would put them out of the price range for the quote. As well, the need for multiple set-ups would potentially decrease the quality of the product.

Solution:

SupplyPoint® engineers processed the part for the company and worked up a process reducing the need for only one set-up, thus ensuring the quality of the product. In addition, SupplyPoint® created a holding fixture that helped reduce the cycle time to 18.5 minutes and generated a savings of 840 machine hours, resulting in an overall cost savings of \$63,000.00. This cost savings has enabled the company to lower their quote, greatly enhancing the opportunity to receive an award, which has a potential contract value of well over \$250,000.00.